

Circuit Design Company
600 W. Roush Street
Danville, KE, 44444

February 9, 2009

Discrete Mathematicians
600 W. Walnut Street
Danville, KY 40244

Dear Discrete Mathematicians:

I work for a digital circuit company, The Circuit Design Company, here in Danville. Recently, my company was approached by a digital clock manufacturer that is trying to develop a new digital clock that will also function as an MP3 player. I have several experienced circuit designers on staff who are working on this project; however, I am not happy with the work they have put forth. Below, you will find the design for one of the circuit components of the clock.

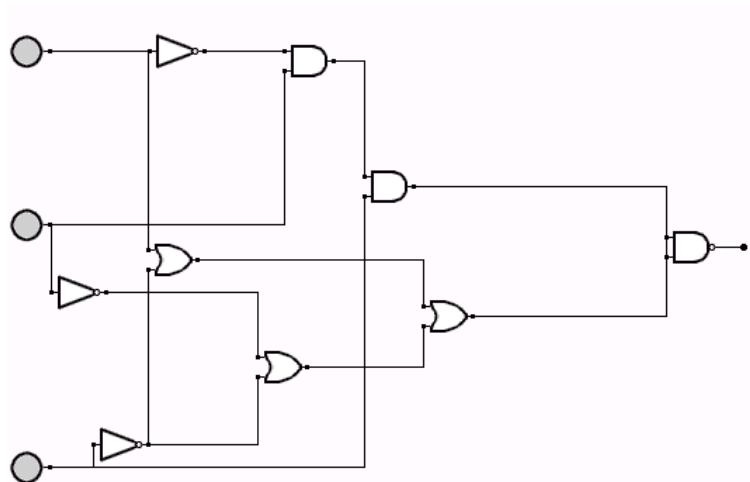

I am afraid to admit that I am not an expert in the circuit design field. I was hired by The Circuit Design Company mainly to oversee the company's finances. However, it seems as though this component should be able to be simplified. If it can be, this would save my company and the clock manufacturers, a great deal of money and energy. This is why I am appealing to you. It was your intrepid and enterprising professor, Dr. Wiglesworth, who referred me to you.

Can this circuit be minimized and still produce the same output? If so, how? Please give me the details on your efforts so that, in the future, I will hopefully be able to solve similar problems. If there is any way that you can help me with this dilemma, I'd be incredibly grateful. I would appreciate an answer as soon as possible, but certainly no later than February 23rd, as our work is due to the clock manufacturer the following week.

Yours Sincerely,

Cigol Setag, Manager
The Circuit Design Company